

# PHOTON

## PHOTON-8H TRAFFIC WARNING LIGHT



### FEATURES

- EN12352 L8H certified high power warning output.
- Low AMP-draw 1 LED design.
- Precision optics design for even and seamless light output
- Choice of clear or amber lens.
- Self-contained flasher; optional external flasher control ready.
- Auto-dim function w/ photocell.
- Smart designed for easy clip mount or surface mount installation.
- Weatherproof and vibration resistant design for harsh work environment.
- Multi-units synchronization in simultaneous or alternating flash.
- Reverse polarity protection.

### SPECIFICATIONS

**Compliance:** EN12352 L8H (P1;C1;R0;A0;I0;F3;O1;M3;T2;S0)  
ECE R10; IPX6; WEEE

**Luminous Intensity :** 2200 cd w/ Amber Lens  
1800 cd w/ Clear Lens

**Operating Voltage:** 12~24VDC

**Warning Patterns:** Steady or Single Flash

**LED Elements:** High power LED x 1 pc

**Average Current (day/night):** 0.16A / 0.06A@12V  
0.08A / 0.028A @24V

**Max. Current (day/night):** 0.32A / 0.12A @12V  
0.16A / 0.06A @24V

**Average Power (day/night):** 1.92W / 0.72W

**Max. Power (day/night) :** 3.84W / 1.44W

**Wires:** Red-Vcc: 20AWG

Black-GND: 20AWG

Yellow-Flash Patterns & Sync\*: 20AWG

\*Available on selected models only

**Synchronization:** up to 20 units

**Fuse Rating:** 1A

**Working Temp.:** -40°C~65°C

**LED Colour:** Amber or White

**Lens Colour:** Amber or Clear

**Lens Material:** Polycarbonate

**Weight :** 0.437kg

**Warranty (Years):** 2



### DIMENSIONS

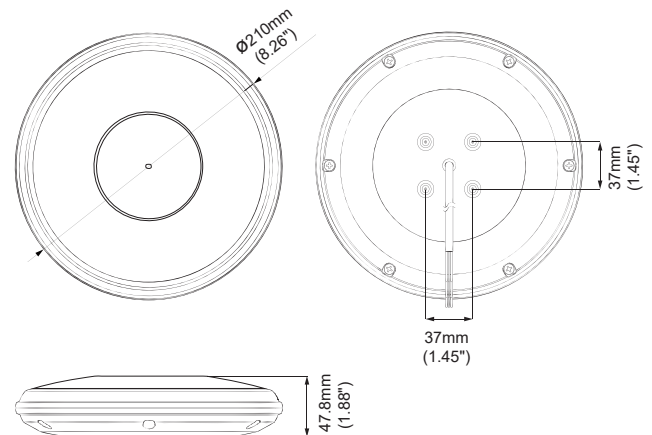

### FLASH PATTERN

	Warning Flash Pattern	Power Consumption	Flash Frequency
1	Steady	-	-
2	Single (1Hz) Auto-dim Enable	3.85 Ah/day	60 FPM
3	Single (1Hz) Auto-dim Disable	-	60 FPM

### PART NO.

- M071-0xy3z-00R

Replace **x** for mounting option:

- 0 = Surface mount
- 1 = Surface mount w/ Rubber riser block
- 2 = U-bolt clamp mount w/ Rubber riser block

Replace **y** for colour combination:

- 0 = Amber base w/ 3-wire Cable, 25cm
- 1 = Amber base w/ 3-wire Cable, 500cm
- 2 = Amber base w/ 2-wire Cable, 25cm
- 3 = Amber base w/ 2-wire Cable, 500cm

Replace **z** for colour combination:

- C = Amber LED w/ Clear lens
- 5 = White LED w/ Amber lens

### ACCESSORIES & SERVICE PARTS

- 99-M071W00-000 (2-wire Extension Cable, 5m w/ Waterproof Connector)
- 99-M071W01-000 (3-wire Extension Cable, 5m w/ Waterproof Connector)
- 99-M071W02-000 (2-wire Extension Cable, 15m w/ Waterproof Connector)
- 99-M071W03-000 (3-wire Extension Cable, 15m w/ Waterproof Connector)
- 99-M071M01-000 (Rubber Riser Block)
- 99-M071M02-000 (U-bolt Clamp w/ Rubber Riser Block)