

LP26 LED PAD

12~24VDC

12-LED ULTRA LOW PROFILE WARNING LIGHTHEAD



FEATURES

- World's No.1 - Ultra low profile 6.6mm lighthouse w/ SAE & ECE R65 Class 1 approval.
- Versatile installation in Horizontal mount or Vertical mount; either way meets SAE requirement.
- Double stack design w/ built-in selectable flash patterns in simultaneous or split flash.
- Self-Adhesive backing for quick & easy installation.
- Multi-Voltage Input 12~24VDC.
- Self-contained; no external flasher required.
- Multi-units synchronization in simultaneous or alternating flash.
- Reverse polarity protection.
- Weatherproof and vibration resistant design for external or internal use.
- Solid aluminium backing for efficient heat dissipation and maximum durability.

SPECIFICATIONS

Compliance: SAE J595 Class 1, SAE J845 Class 1, ECE R65 Class 1, ECE R10 CA13, IPx7.

LED Elements: High-power LED x 12pcs

No. of Warning Patterns: 30

Operating Voltage: 12~24VDC

Avg. Current: 0.715A @12VDC / 0.357A @24VDC (varies with flash pattern)

Max. Current: 1.43A @12VDC / 0.715A @24VDC

Avg. Power: 8.6 Watt (varies with flash pattern)

Max. Power: 17.2 Watt

Wires: White - Vcc : 20cm (24AWG)

Black - GND : 20cm (24AWG)

Brown - Flash Patterns & Sync : 20cm (24AWG)

Fuse Rating: 2A

Synchronization: up to 20 units

LED Colour: Red, Blue, Amber, White

Lens Colour: Clear

Storage Temp.: -40°C to +75°C

Working Temp.: -30°C to +65°C

DIMENSIONS

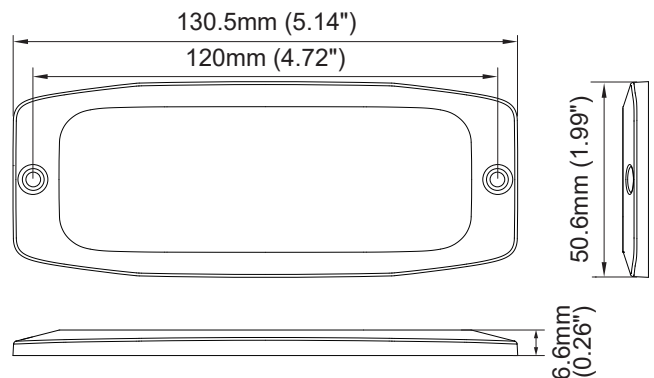

FLASH PATTERN

FP#	Flash Pattern			
1	Double	[R65]*	16	Single H/L
2	Single	[2Hz]	17	Single-Triple-Quint
3	Triple	[2Hz]	18	Half-Steady-Half-Double (Split)
4	Quad	[2Hz]	19	Single (Split)
5	Random		20	Double (Split)
6	Steady / Cruise		21	Triple (Split)
7	Single	[SAE/CA13]	22	Quad (Split)
8	Double	[SAE]	23	Quint (Split)
9	Triple	[SAE]	24	Mega (Split)
10	Quad	[SAE]	25	Giga (Split)
11	Quint	[SAE]	26	Ultra (Split)
12	Mega		27	Single-Quad (Split)
13	Giga		28	Single H/L (Split)
14	Ultra	[SAE]	29	Single-Triple-Quint (Split)
15	Single-Quad		30	Steady-Dim EF**

(Split) = Top-half alternating Bottom-half.

* Actual approval will be based on the model purchased.

** For use with external flash controller.

PART NO.

- 02130224 (Amber)
- 02130231 (Blue)
- 02130248 (Red)
- 02130255 (White)