

ST26 Super Thin

12-LED Directional Warning Lamp (Surface Mount)

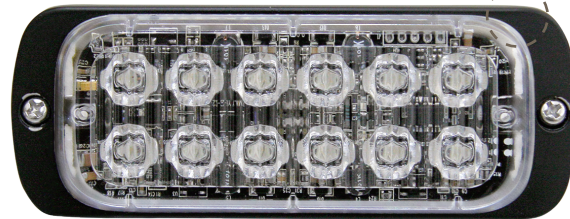
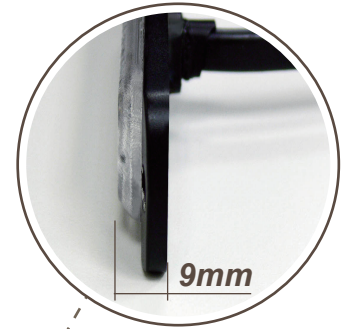
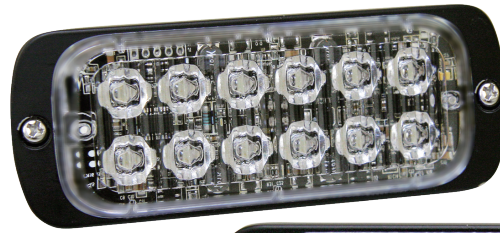

FEATURES

- 0.35" (9mm) Super low-profile thickness.
- Multi-Voltage Input 12~24VDC
- Built-in 25 selectable flash patterns
- LEDs rated to 100,000 hours of operation.
- Non-volatile memory recalls last flash pattern used at power up.
- Multi-units synchronization in simultaneous or alternating flash.
- Reverse polarity protection.
- Weatherproof and vibration resistant design for internal or external use.
- Aluminum base for heat dissipation.

SPECIFICATIONS

- Meets:** SAE J595 Class 1(R,A,B,W) ;
ECE R65 Class 2(A,B) ; ECE R10
- Bulb:** High-power LED x 12pcs
- Warning Patterns:** 25 Flash Patterns
- Operating Voltage:** 12~24VDC
- Avg. Current:** 0.78A @12VDC / 0.39A @24VDC
(varies with flash pattern)
- Avg. Power:** 9.25 Watts (varies with flash pattern)
- Max. Current:** 1.56A @12VDC / 0.78A @24VDC
- Max. Power:** 18.5 Watts
- Wires:** Red-Vcc : 25cm (20AWG)
Black-GND : 25cm (20AWG)
Yellow-Flash Patterns & Sync : 25cm (20AWG)
White-Low Power : 25cm (20AWG)
- Fuse Recommended:** 3A
- Multi-Unit Synchronization:** Over 15 units
- Available in:** RED, BLUE, AMBER, WHITE

DIMENSIONS

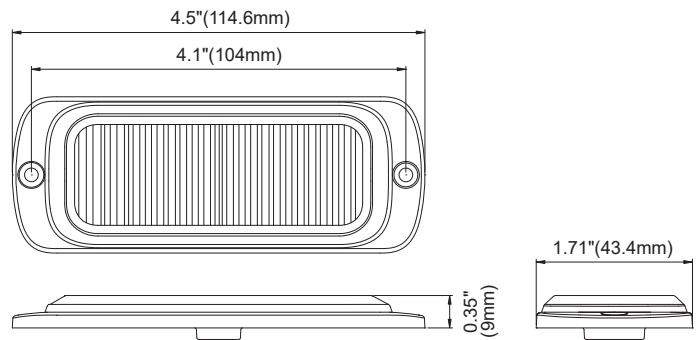

PART NO.

- M62-1130C-00R (AMBER)
- M62-1130B-00R (BLUE)
- M62-1130R-00R (RED)
- M62-1130W-00R (WHITE)
- M62-2130C-00R (R65, AMBER)
- M62-2130B-00R (R65, BLUE)

FLASH PATTERN

FP#	Flash Patterns		
1	Double [R65]	14	Single (all) [SAE]
2	Single [2Hz]	15	Double (all) [SAE]
3	Triple [2Hz]	16	Quad (all) [SAE]
4	Quad [2Hz]	17	Quint (all) [SAE]
5	Random	18	Mega (all)
6	Single (split)	19	Ultra (all) [SAE]
7	Double (split)	20	Single-Quad (all)
8	Quad (split)	21	Single H/L (all)
9	Quint (split)	22	Steady half
10	Mega (split)	23	Steady all
11	Ultra (split)	24	Rotate Slow
12	Single-Quad (split)	25	Rotate Fast
13	Single H/L (split)		

*split=Left alternating Right *all=all LEDs on