

# WLG series

## ROUND LED Work Lamp

### Flood Beam

#### FEATURES

- Multi-Voltage Input 10~80VDC.
- Heavy-Duty Powder Coated Die Cast Aluminium
- Weatherproof and Vibration resistant
- LEDs rated to 50,000 hours of operation
- Reverse Polarity Protection
- Applications: Police, Fire, Ambulance, Tow, Agriculture, Construction, Mining, Off-road, Marine

#### SPECIFICATIONS

Compliance: EMC, IPX9K

LED Element: High Intensity LED x 4pcs

	WLG-Flood
Raw Lumen	900lm
Effective Lumen	400lm
LED Current	0.55 Amps
Operates Voltage	9-50VDC
Max. Current (Amps)	1.2A @9VDC
	0.2A @50VDC
Max. Power	10.8 Watts

Wires: Red-Vcc: 18AWG / 38cm

Black-GND: 18AWG / 38cm

Fuse Rating: 3 Amps

Storage Temperature: -40°C to +75°C

Operating Temperature: -30°C to +50°C

#### DIMENSIONS

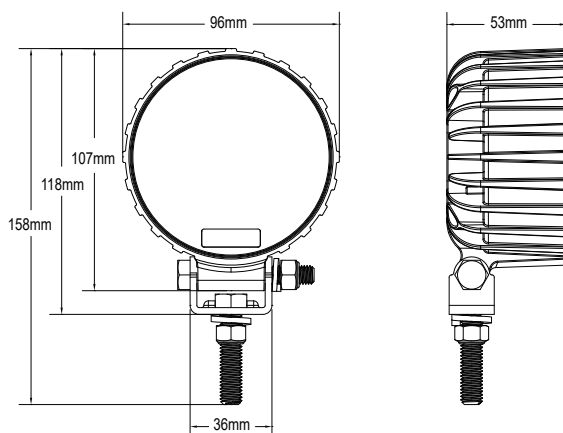

#### PART NO.

- 07010903 (Flood Beam)

#### BEAM PATTERN

Flood (900lm)

Side view

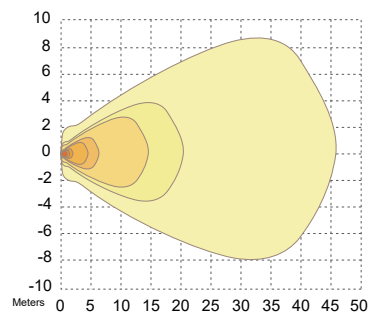

Top view

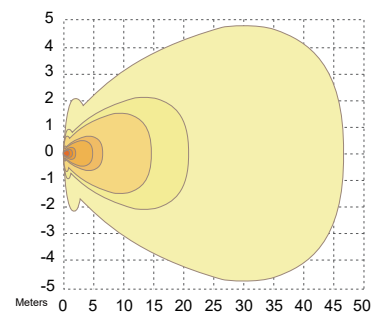

# WLH series SQUARE LED Work Lamp



## FEATURES

- Flood Beam
- Multi-Voltage Input 12~24VDC.
- Heavy-Duty Powder Coated Die Cast Aluminum
- Weatherproof and Vibration resistant
- LEDs rated to 50,000 hours of operation
- Reverse Polarity Protection
- Applications: Police, Fire, Ambulance, Tow, Agriculture, Construction, Mining, Off-road, Marine

## SPECIFICATIONS

**Meets:** EMC

**LED Element :** High Intensity LED x 4pcs

**LED Current :** 0.37 Amps

**Operates Voltage :** 12-24VDC

**Max. Current (Amps) :** 0.6A @12.8VDC / 0.3A@25.6VDC

**Max. Power :** 7.5 Watts

**Raw Lumen:** 400lm

**Cable Length:** 38cm

**Wire Functions:** Red - Vcc

Black - GND

**Fuse Rating:** 1 Amps

## PART NO.

- 07011009

## DIMENSIONS

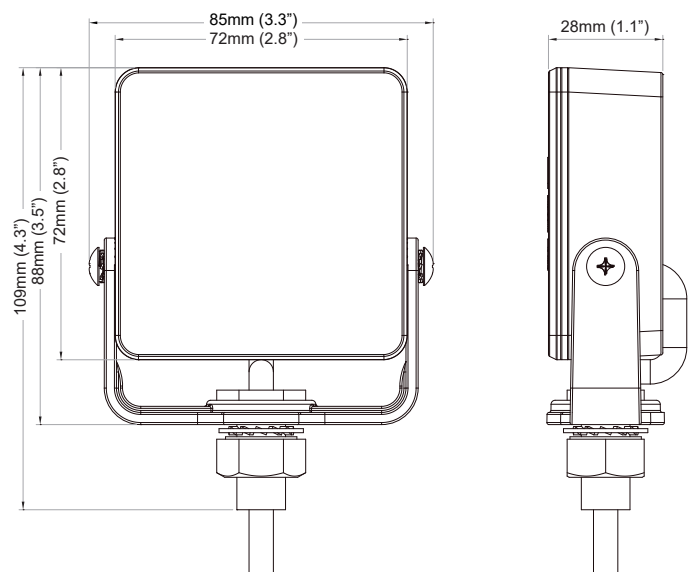

## MOUNTING BRACKETS

- 07010057

Plastic U-Bracket



- 07010064

Metal U-Bracket



- 02150031

L-Bracket

