

MINI L-BRACKET KIT For Traffic Advisor Warning Stick

FOR EACH BRACKET:

- A • Carriage Bolt x 1pc
- B • Foam Pad x 1pc
- C • Self-Drilling Screw x 2pcs
- D • Flat Washer x 4pcs
- E • Spring Washer x 1pc
- F • Elastic Stop Nut x 1pc

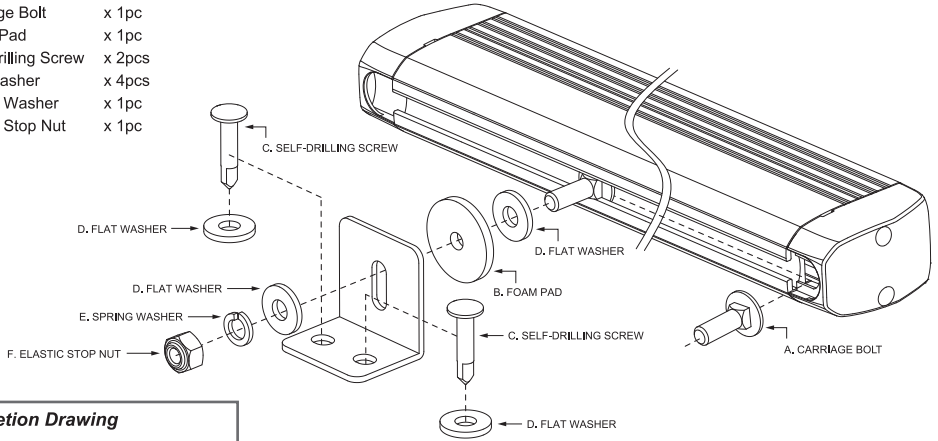

Completion Drawing

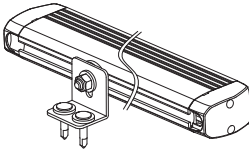

ASSEMBLING NOTE:

1. For 2-head to 8-head stick, use at least 2 brackets for each stick.
2. For 10-head stick, use at least 3 brackets for each stick.
3. Set torque force @ 45 ± 5 Kgf-cm (40 ± 4 lbf-in) for all Elastic Stop Nuts.

STANDARD L-BRACKET KIT For Traffic Advisor Warning Stick

FOR EACH BRACKET:

- A • Carriage Bolt x 1pc
- B • Foam Pad x 1pc
- C • Self-Driling Screw x 2pcs
- D • Flat Washer x 4pcs
- E • Spring Washer x 1pc
- F • Elastic Stop Nut x 1pc

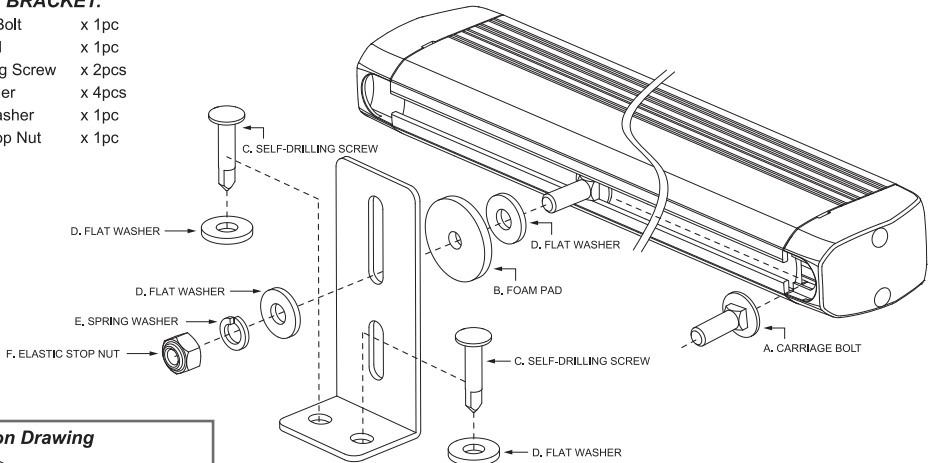

Completion Drawing

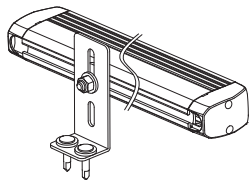

ASSEMBLING NOTE:

1. For 2-head to 8-head stick, use at least 2 brackets for each stick.
2. For 10-head stick, use at least 3 brackets for each stick.
3. Set torque force @ 45 ± 5 Kgf-cm (40 ± 4 lbf-in) for all Elastic Stop Nuts.

SURFACE BRACKET KIT *For Traffic Advisor Warning Stick*

FOR EACH BRACKET:

- A • Carriage Bolt x 1pc
- B • Foam Pad x 1pc
- C • Self-Drilling Screw x 2pcs
- D • Flat Washer x 4pcs
- E • Spring Washer x 1pc
- F • Elastic Stop Nut x 1pc

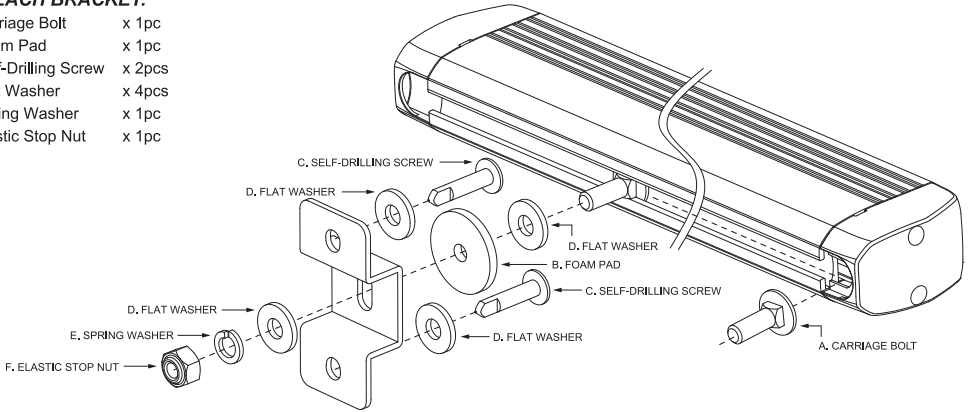

Completion Drawing

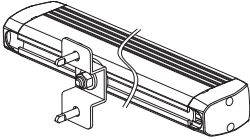

ASSEMBLING NOTE:

1. For 2-head to 8-head stick, use at least 2 brackets for each stick.
2. For 10-head stick, use at least 3 brackets for each stick.
3. Set torque force @ 45 ± 5 Kgf-cm (40 ± 4 lbf-in) for all Elastic Stop Nuts.

ADJUSTABLE-BRACKET KIT *For Traffic Advisor Warning Stick*

FOR EACH BRACKET:

- A • Carriage Bolt x 1pc
- B • Foam Pad x 1pc
- C • Self-Drilling Screw x 2pcs
- D • Flat Washer x 4pcs
- E • Spring Washer x 1pc
- F • Elastic Stop Nut x 1pc
- G • Screw x 4pcs
- H • Lock Washer x 4pcs

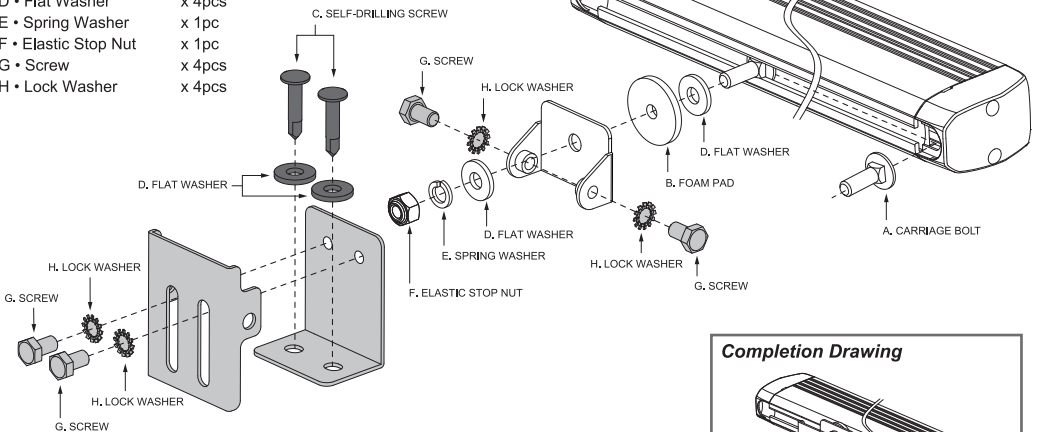

Assembling Sequence:

- Step 1
- Step 2
- Step 3

ASSEMBLING NOTE:

1. For 2-head to 8-head stick, use at least 2 brackets for each stick.
2. For 10-head stick, use at least 3 brackets for each stick.
3. Set torque force @ 45 ± 5 Kgf-cm (40 ± 4 lbf-in) for all Elastic Stop Nuts.

Completion Drawing

