

# EC Series

## LED WORK LAMPS

### FEATURES

- ECE approved for use as highly effective Reversing Lamps.
- Premium brand Osram LED devices used.
- Robust construction and Stainless fasteners for long life.
- Low current consumption and high luminous output.
- 6000K for excellent illuminated area colour rendering.

### SPECIFICATIONS

#### Compliance:

**EC9S:** ECE R10; RoHS; CE; ECE R148 Reverse (ECE R23)  
[Angle from vertical: 20 degrees down]

**EC9R:** ECE R10; RoHS; CE

**EC16R:** ECE R10; RoHS; CE; ECE R148 Reverse (ECE R23)  
[Angle from vertical: 10 degrees down]

**Ingress Protection:** IP67

**Colour Temp:** 6000K

**Beam Type:** Flood

**Body Material:** Aluminium - Powder Coated - Black

**Lens Material:** Polycarbonate

**Bracket Material:** Stainless Steel - 201 - Natural

**Fasteners Material:** Stainless Steel - 304 - Natural

**Warranty:** 2 years

| Cell2 Designation | Cell2 Part Number | Raw Lumens | Effective Lumens | Qty. of LEDs | Input Voltage | Current @ 12V (A) | Current @ 24V (A) | Power Consumption (W) |
|-------------------|-------------------|------------|------------------|--------------|---------------|-------------------|-------------------|-----------------------|
| EC9S              | 07070013          | 1710       | 1670             | 9            | 10-33VDC      | 1.25              | 0.65              | 15                    |
| EC9R              | 07070020          | 1710       | 1670             | 9            | 10-33VDC      | 1.25              | 0.65              | 15                    |
| EC16S             | 07070037          | 3040       | 2680             | 16           | 10-33VDC      | 2.08              | 1.05              | 25                    |

### PART No.

- 07070013 - EC9S
- 07070020 - EC9R
- 07070037 - EC16S



**EC9S**



**EC9R**



**EC16S**

### DIMENSIONS

**EC9S**

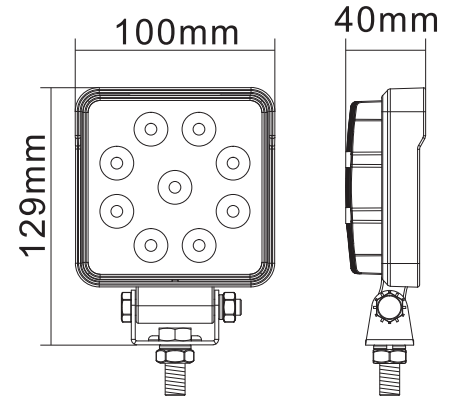

**EC9R**

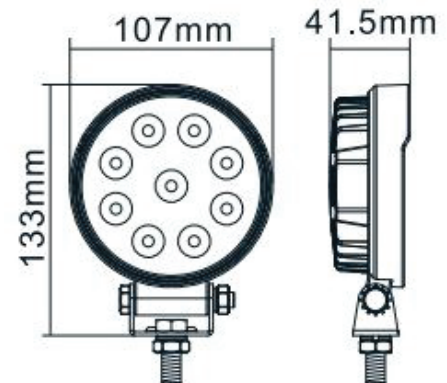

**EC16S**

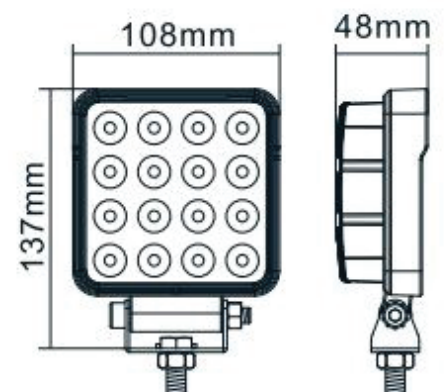

**NOTE:** The diagrams are not represented to scale.