

HL Series

LED WORK LAMPS



HL4S



HL9S

FEATURES

- Classic styling, modern performance.
- One version approved as highly effective Reversing Lamp.
- Low current consumption and high luminous output.
- Premium brand Osram LED devices used.
- Robust construction and Stainless Fasteners for long life.

SPECIFICATIONS

Compliance:

HL4S: ECE R10; RoHS; CE;
ECE R23 [Angle from vertical:
52 degrees down]

HL9S: ECE R10; RoHS; CE

IP Ratings: IP67

TCS (Temperature Control System): YES

Body Material: Aluminium - Powder Coated - Black

Lens Material: Polycarbonate

Bracket Material:

HL4S: Stainless Steel - 201 - Natural

HL9S: Stainless Steel - 304 - Natural

Fasteners Material: Stainless Steel - 304 - Natural

Warranty : 2 years

DIMENSIONS

HL4S

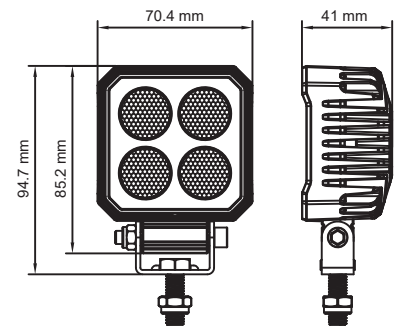

HL9S

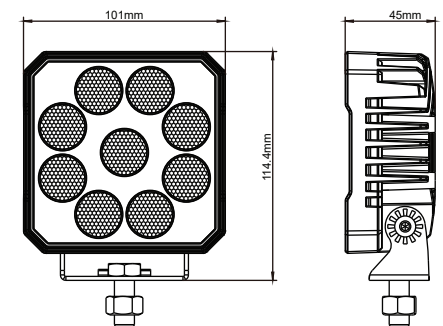

NOTE: The diagrams are not represented to scale.

Cell2 Designation	Cell2 Part Number	TCS (Temperature Control System)	Raw Lumens	Effective Lumens	Affective Lumens Low (TCS)	Colour Temp	Qty. of LEDs	Input Voltage	Current @ 12V (A)	Current @ 12V (A) Low (TCS)	Current @ 24V (A)	Current @ 24V (A) Low (TCS)	Power Consumption (W)
HL4S	07080012	Yes	2750	2200	1400	6000K	4	10-33VDC	2.00	1.32	1.10	0.70	27
HL9S	07080029	Yes	6700	5200	2780	5700K	9	10-33VDC	4.29	2.40	2.25	1.30	55